

# ***PROVECTA V***

## Mobile Veterinary X-Ray System

### Operator's Manual



 ALLPRO IMAGING

**AIR**  
**TECHNIQUES**  
INC.

# TABLE OF CONTENTS

---

Introduction .....	4
Warranty .....	4
On-Line Warranty Registration .....	4
Key Features .....	5
Safety Notice .....	5
General Safety Precautions .....	6
Protection Against Radiation Warning .....	6
Symbols Used .....	6
Knowledge of Warnings .....	7
Warnings .....	7
Environmental Risk and Disposal .....	7
Cleaning and Disinfecting .....	8
Product Description .....	8
Key Components .....	8
Provecta V Mobile System Parts Identification .....	9
Technical Specifications .....	10
Technical Features .....	10
Tubehead Features .....	10
X-Ray Tube Features .....	11
Environmental Conditions .....	11
Apparatus and Detachable Parts Weight .....	11
Selected Exposure Time and Corrected Actual Exposure Time .....	11
Exposure Time Correction Factors vs Line Voltage .....	12
Technical Factors Measuring Method .....	13
X-Ray Tube Curves .....	13
X-Ray Tubehead Components .....	14
X-Ray Tubehead Specifications .....	15
Filament Characteristics .....	15
Filament Loading .....	15
X-Ray Tubehead Cooling .....	16
Cooling Curve of Tubehead .....	16
System Portability .....	17
System Activation .....	18
X-Ray Control Panel Functions .....	18
Keypad Operation .....	20
Increase Select Button .....	20
Decrease Select Button .....	20
Tooth Select Mode Select Button .....	20
Size Mode Select Button .....	21
Digital/Film Mode Select Button .....	21
Default Exposure Time Settings .....	21

# TABLE OF CONTENTS

---

<b>Keypad Operation: Custom Programming</b> .....	22
Changing Default Settings to Customized Values .....	22
Changing Display to Pulses .....	22
Changing Display to Seconds .....	22
Changing Default Tooth Settings .....	23
Changing Default Large and Small Multiplier Ratio .....	23
Changing Film Multiplier Ratio Settings .....	24
Changing Digital Multiplier Ratio Settings .....	24
Factory Reset .....	24
<b>System Operation</b> .....	25
Setting the Exposure .....	25
Automatic Exposure Time Selection .....	25
Manual Exposure Time Selection .....	26
Exposure Emission Procedure .....	27
Reading the Exposure Counter .....	27
<b>System Reach and Storage Dimensions</b> .....	28
<b>Radiographic Troubleshooting</b> .....	29
<b>System Maintenance</b> .....	31
<b>System Error Messages</b> .....	31
<b>Notes</b> .....	35

## INTRODUCTION

---

Congratulations, your new PROVECTA V Veterinary X-ray (hereafter referred to as PROVECTA V) has been engineered and manufactured to provide you with years of reliable service.

The PROVECTA V provides a mobile x-ray solution for veterinary applications that creates radiographs of excellent quality. It performs equally well using digital or film-based imaging media.

Review and follow the guidelines included in this manual to thoroughly become familiar with the installation, maintenance, operating and safety procedures. This will ensure that your PROVECTA V gives you the highest level of service.

Your PROVECTA V Veterinary X-Ray model A2100V contains the following components:

ITEM	PART NUMBER
Scissor Arm	A2120
70kVp 8mA Tubehead	A2250
X-ray Control Panel	A2750V
X-ray Arm Support Platform	A2615
Mounting Hardware	A2710
Users Manual	A2741V
Service Manual	A2508V
Warranty Registration Information Card	9922-190
Form FDA 2579	N/A

## WARRANTY

---

The PROVECTA V X-ray is warranted to be free from defects in material and workmanship from the date of installation for a period of twenty-four (24) months.

Any item returned to our factory in Hicksville, New York, during the warranty period, through an ALLPRO Imaging **authorized dealer**, will be repaired or replaced at our option at no charge provided that our inspection shall indicate it to have been defective. Dealer labor, shipping and handling charges are not covered by this warranty.

This warranty does not apply to damage due to shipping, misuse, careless handling or repairs by other than authorized service personnel. ALLPRO Imaging is not liable for indirect or consequential damage or loss of any nature in connection with this equipment.

This warranty is in lieu of all other warranties express or implied. No representative or person is authorized to assume for us any liability in connection with the sale of our equipment.

## ON-LINE WARRANTY REGISTRATION

---

Quickly and easily register your new PROVECTA V on-line. Just have your product model and serial numbers available. Then go to the ALLPRO website, [www.allproimaging.com](http://www.allproimaging.com), click the **warranty link** and complete the registration form. This on-line registration ensures a record for the warranty period and helps ALLPRO keep you informed of product updates and other valuable information.

## KEY FEATURES

1. Microprocessor controlled.
2. Exposure compensation over input AC voltage range.
3. User selectable exposure time in seconds/pulses.
4. 30 preset exposure times.
5. 44 Manually selectable exposure times.
6. Programmable Size ratios.
7. Programmable Film setting.
8. Programmable Digital setting.
9. Two memorized exposure settings.
10. Stable positioning.
11. X-ray Control Panel.
12. Handheld Exposure Switch.
13. Designed for ease of use.
14. Built in tubehead simulator for training and testing the X-Ray Control operation.

## SAFETY NOTICE

### **ATTENTION USERS:**

MANUFACTURING DATE CODE ON SERIAL NUMBER LABEL IS IN THE FORMAT: Month YYYY.



Alerts users to important Operating and Maintenance instructions. Read carefully to avoid any problems.



Warns users that uninsulated voltage within the unit may be of sufficient magnitude to cause electric shock.



Indicates type BF equipment in accordance with IEC 601-1



MEDICAL ELECTRICAL EQUIPMENT

WITH RESPECT TO ELECTRICAL SHOCK, FIRE, MECHANICAL AND OTHER SPECIFIED HAZARDS ONLY  
IN ACCORDANCE WITH UL-60601-1, CAN/CSA C22.2 NO.601.1  
66CA

### **DO NOT ATTEMPT INTERNAL SERVICE**

The interior of the Main Assembly is only accessible by removing hardware with tools and should only be opened and serviced by an authorized ALLPRO Imaging Dealer Service representative. Call your authorized ALLPRO Imaging dealer for service. Since the interior of the unit contains high voltage components, failure to heed this warning may result in equipment damage, personal injury and/or death.

# SAFETY NOTICE

---

## GENERAL SAFETY PRECAUTIONS

This equipment has been designed and manufactured in compliance with applicable safety requirements; moreover, this manual provides all the necessary information for correct and safe utilization. It provides warnings related to risks associated with the PROVECTA V and should be read very carefully. ALLPRO Imaging Inc. shall not be responsible for:

- any use of PROVECTA V equipment different from that for which it was been designed,
- any damage to the equipment, the operator or the patient caused either by incorrect installation or maintenance not compliant with the procedures contained in the relevant user's and installation manuals provided with the equipment, or by incorrect operation techniques,
- any mechanical and/or electrical changes made during or after installation, different from those specified in the service manual.

Only qualified service personnel, authorized by ALLPRO Imaging, Inc., or its dealers are allowed to perform repairs on the equipment.





## PROTECTION AGAINST RADIATION WARNING:

Radiation protection is generally prescribed or regulated by local, State or Federal regulatory agencies. These regulations are beyond the scope of this manual. Operation and use of the device should be limited to trained personnel in accordance with local, state and federal regulations.

- a. The film, phosphor plate or sensor must be introduced in the patient's mouth either manually or by means of appropriate holders; it must never be held by the operator.
- b. During radiation exposure, the operator must not be in contact with the tubehead or the collimator.
- c. During radiation exposure, the operator must keep at a certain distance from the X-ray source (at least 6-1/2 feet), in a direction opposite to that of X-ray emission.
- d. During radiation exposure, no one other than the operator and the patient must be present in the room.

## SYMBOLS USED

The following symbols are used on the PROVECTA V and in this manual.

~	AC
N	Connection to Neutral Conductor
L	Connection to Line Conductor
	Protection Grounding
	Functional Grounding
	OFF; Equipment not Connected to Power Line
	ON; Equipment Connected to Power Line
	X-ray Emission

## KNOWLEDGE OF WARNINGS

Users must exercise every precaution to ensure personnel safety, and be familiar with the warnings presented throughout this manual and summarized below.

## WARNINGS:

Federal law restricts this device to sale by or on the order of a Veterinarian.

This equipment complies with DHHS performance standard 21 CFR Subchapter J.

This equipment complies with the requirements of IEC 60601-2-7, and UL 60601-1.

The X-ray Tubehead Assembly P/N A2250 complies with IEC 60601-2-28 (1993).

The equipment must be used in compliance with the procedures contained in this manual and shall not be used for purposes different from those described in this manual.

PROVETA V is classified as veterinary dental imaging equipment and must therefore be used only under the supervision of qualified veterinary staff, having the necessary knowledge in the field of radiation.

The user bears legal responsibility related to the possession, installation and use of this device. *Do not remove panels.* Removing panels would create an electric shock hazard.

Equipment is not suitable for use in the presence of flammable anesthetic mixture with air or with oxygen or nitrous oxide.

For continued protection against risk of fire, replace only with the same type and rating of circuit breakers and fuses.

Replace components only with authorized replacement parts identified in this manual.

Before performing any maintenance, the equipment must be disconnected from the AC power source.

Do not allow water or other liquids to penetrate inside the equipment to avoid short circuits and corrosion.

**Although the x-ray doses provided by modern equipment are reduced as low as reasonably possible, during exposure the operator must take all the necessary precautions and/or protection measures for the patient and themselves, in compliance with existing regulations.**

PROVETA V must be switched off during the use of High Frequency surgical devices or similar instruments placed near the equipment.

Do Not place ANY additional weight on the scissor arms.

**Note:** ALLPRO Imaging, Inc., is not responsible for disposal of the apparatus or parts thereof and for the related expenses.

## ENVIRONMENTAL RISK AND DISPOSAL

The equipment contains - in some of its parts - solid and liquid substances which must be disposed of at appropriate recycling centers conforming to all local, state and federal regulations.

In particular, the equipment contains the following materials and/or components:

**Tubehead:** non-biodegradable plastic materials, metals, glass, dielectric oil, lead, tungsten.

**Other parts of the equipment:** non-biodegradable plastics, metals, printed circuits, and electronic components.

# CLEANING AND DISINFECTING

---

## CLEANING AND DISINFECTING PROCEDURES

In order to ensure proper hygiene and cleaning of the equipment, the following procedures must be followed thoroughly:

**Warning: Disconnect the branch circuit breaker or AC power source before performing cleaning procedures. Active internal circuits remain connected to main voltage even when main power switch is turned off.**

**Exterior Surfaces:** Wipe the outside surfaces with a paper towel dampened with a disinfectant solution or household, non-abrasive cleaner. DO NOT SPRAY SOLVENTS OR LIQUID DIRECTLY ON THE X-RAY UNIT. BE CAREFUL NOT TO ALLOW SOLVENTS TO RUN OR DRIP into the PROVECTA V. This could cause damage to the PROVECTA V. Allow to air dry before plugging in or turning back on.

**Parts in Contact with the Patient 's Skin:** To ensure proper cleaning of these parts, periodic disinfection with an approved EPA Non Corrosive Surface Disinfectant such as Birex® se is recommended.

## PRODUCT DESCRIPTION

---

### KEY COMPONENTS

PROVECTA V equipment is comprised of the following components:

- a. **Scissor Arm** - The scissor arm consists of inboard and outboard arms joined by a double joint. This allows linear and upward extension enabling the tubehead to remain balanced in all positions.
- b. **Tubehead with Beam Limiting Device** - 70 kVp voltage and 8 mA current reduce exposure times and the amount of radiation absorbed by the patient. The tubehead is equipped with a beam limiting device providing a 20 cm (8 inches) source to skin distance and a 6 cm (2 3/8 inches) beam diameter at the output. Mechanically, the tubehead is connected to the arm by means of a rotating contact, allowing 360-degree horizontal rotation and 285-degree vertical rotation.
- c. **X-Ray Control Panel** - The X-ray Control Panel is a microprocessor-controlled digital timer that permits both manual selection and 5 automatic selections of exposure times. An automatic selection function further allows the operator to choose among 30 pre-set times according to the type of patient (Small, Medium or Large), the type of tooth and digital or film type. Additionally, 44 fixed times can be selected manually and ranges between 0.02 and 3.20 seconds. The integral timer automatically compensates for input line voltage variations within a range of 120 V  $\pm$  10%.
- d. **Mobile X-Ray Support Platform** - Mobile X-Ray Support Platform provides a stable portable operating base for the PROVECTA V.
- e. **Handheld Exposure Switch** - The Handheld Exposure Switch is connected to the X-ray Control Panel via a coiled cable, which allows the operator to start an x-ray exposure cycle while assuring exact tubehead positioning.
- f. **Power Line Cord** - This 16-foot cable connects between an AC wall outlet and the Mobile X-Ray Support Platform to provide connection of the operating 120 AC line voltage.

## Provecta V Mobile System Parts Identification

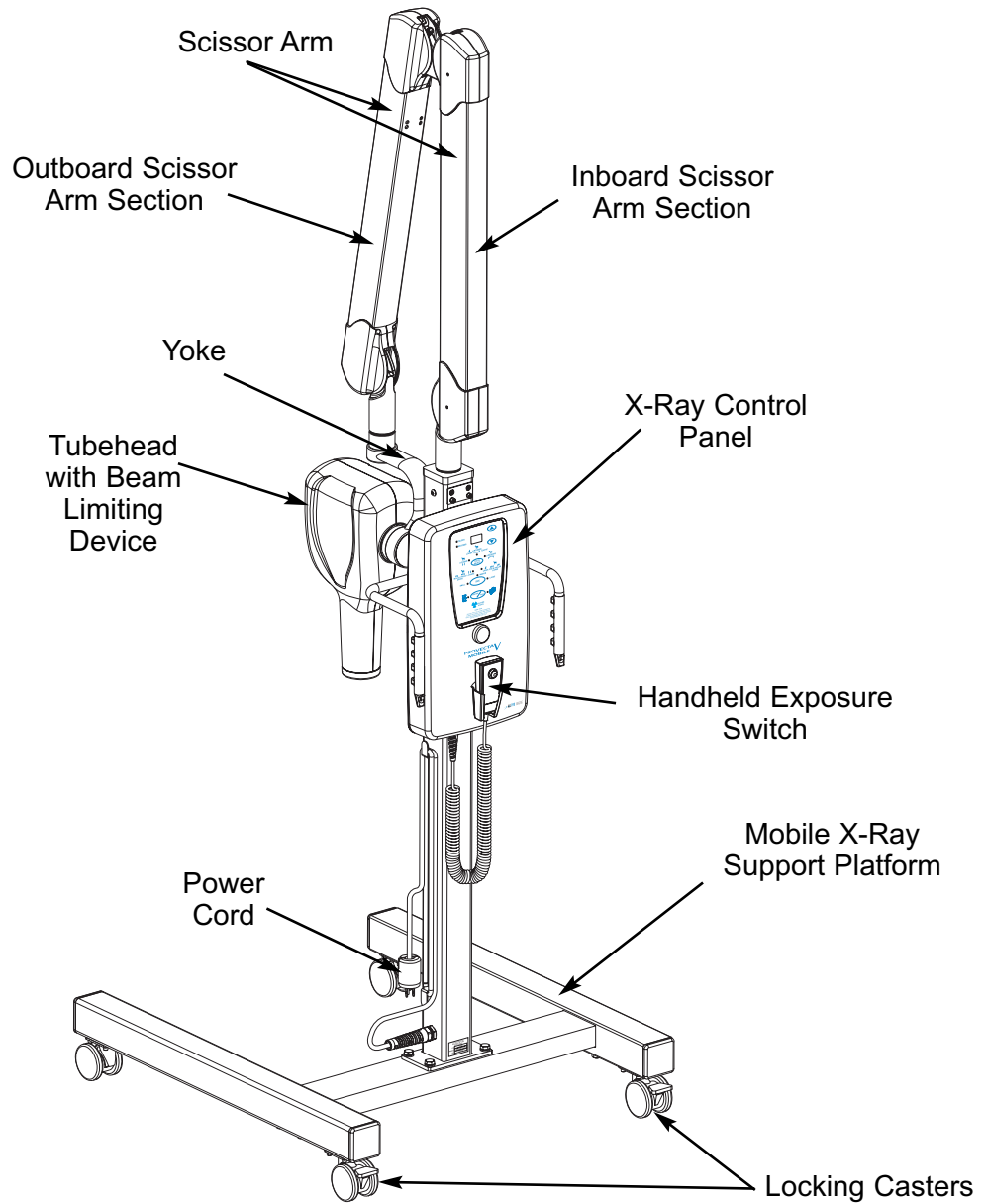

# TECHNICAL SPECIFICATIONS

---

## Technical Features

Equipment Manufacturer	Air Techniques Inc.
IEC 60601-1 Classification	Class I with type B applied parts
Degree of protection against ingress of water	Ordinary

**Note:** Equipment is not suitable for use in the presence of flammable anesthetic mixture with air or with oxygen or nitrous oxide.

Mode of operation	Continuous operation with intermittent loading
FDA 21 CFR Classification	Class II
Line voltage	120V +/- 10%
Line frequency	60Hz
Rated current	8.2 Amps
Power consumption	0.8 kVA @ 120V
Line Voltage Regulation	<3%
Apparent Resistance of Supply Mains	0.43 ohms
Circuit Breakers	10 Amp
Circuit Board Fuses	10A 250V Ceramic Fast Acting (0.25 x 1.25 IN) and 630mA 250V Fast Acting (5 mm x 20 mm)
Preset exposure times	from 0.02 to 3.20 seconds in 44 steps
Anatomic selection	30 pre-set times
Exposure control	Microprocessor controlled exposure times, with automatic compensation for line voltage variations.

**See Selected Exposure Time and Corrected Actual Exposure Time note on page 11.**

## Exposure Time at 120 Volts

Timer Accuracy on the selected Exposure Time (The value of the operator selected timer setting.)	+/- 5% or +/- 33ms of selected Exposure Time (whichever is greater) when the AC input is 120 volts.
--	---

## Corrected Exposure Time at Voltages Other than 120 Volts

Timer Accuracy on the Corrected Exposure Time (The actual time of exposure, indicated on the Control Panel during emission and determined by the internal algorithm as a function of the line voltage). The range of adjustment is 73% to 149% as the AC line voltage changes within the rated voltage range.	+/- 5% or +/- 33ms of Corrected Exposure Time (whichever is greater) when the AC input is other than 120 volts.
---	---

Mobile X-ray dimensions	79½" H x 28" W x 31" D
-------------------------	------------------------

## Tubehead Features

Rated output voltage	70 kVp +/- 15% over 108-132 VAC
High voltage circuit type	108-132 VAC Single phase, self-rectifying
Tubehead current	8 mA +/- 2 mA
Tubehead Power	0.8 kw
Total filtration	2mm Aluminum equivalent @70 kVp
Transformer insulation	Oil bath
Cooling	Convection
Pre-heating time	100ms
Interval between exposure / duty cycle	32 times X-ray time / 1: 32
Beam Limiting Device	Incorporated in Tubehead Assembly (non-removable)
Tubehead Assembly dimensions (less yoke)	5" H x 7.5" W x 15" D

# TECHNICAL SPECIFICATIONS

## Tubehead Features (continued)

Minimum source to skin distance	20 cm (8")
Maximum symmetrical radiation field @ 20 cm (X-ray beam diameter)	2 3/8" (6 cm)
Radiation leakage at 1 m	<50 mR/h, duty cycle 1: 32
Technical factors for radiation leakage	70 kVp, 8mA, 3 seconds

## X-ray Tube Features

Manufacturer	CEI- Bologna- Italy
Type	OCX/70-G
Focal spot	0.8 mm (IEC 336)
Inherent filtration	0.5 mm Al equivalent
Anode thermal capacity	6kJ

## Environmental Conditions

Operating temperature range	+50°F to +104°F (+10°C to +40°C)
Operating relative humidity range	30% - 75%
Temperature range for transport and storage	-4°F to +158°F (-20°C to +70°C)
Max. relative humidity for transport and storage	<95 % non condensing
Minimum atmospheric pressure for storage and transport	0.6 atmospheres

## Apparatus and Detachable Parts Weight

Gross weight including packaging	170 lbs.
Net apparatus weight in standard configuration	155 lbs. (including scissors arm)
Scissors arm	24 lbs.
Tubehead	18.5 lbs.
Mobile Platform with Controller	112.5 lbs.

## Selected Exposure Time and Corrected Actual Exposure Time

The ALLPRO Imaging X-ray Control Panel incorporates a special Timer feature that automatically corrects the selected exposure time when the line voltage varies from 120 V. A change in the AC line voltage affects the peak voltage applied to the X-Ray tube and the value of high voltage significantly affects the spectrum of the radiation that ultimately affects the optical density of the imaging media. The purpose of the X-ray Control timer correction is to obtain the same nominal optical density on the imaging media independent of the AC line voltage variations from 108-132 Volts.

The automatic correction of the exposure time works as follows:

The internal voltage measuring circuit in the X-ray Control Timer continuously monitors the AC line voltage. When the user selects the desired exposure time and presses the X-ray Exposure button, the exposure time will be automatically adjusted based upon the measured AC line voltage. The corrected actual exposure time will be displayed until the X-ray Exposure button is released.

**Note: Electromagnetic interference between the equipment and other devices can occur. Do not use the equipment in close conjunction with sensitive devices, or devices creating high electromagnetic disturbances.**

# TECHNICAL SPECIFICATIONS

---

The corrected exposure is calculated applying a correction factor to the selected exposure time, based on an empirical law that correlates the dose with the high voltage peak and consequently with the line voltage. The qualitative relationship between the multiplying factor and the line voltage is shown in the following picture:

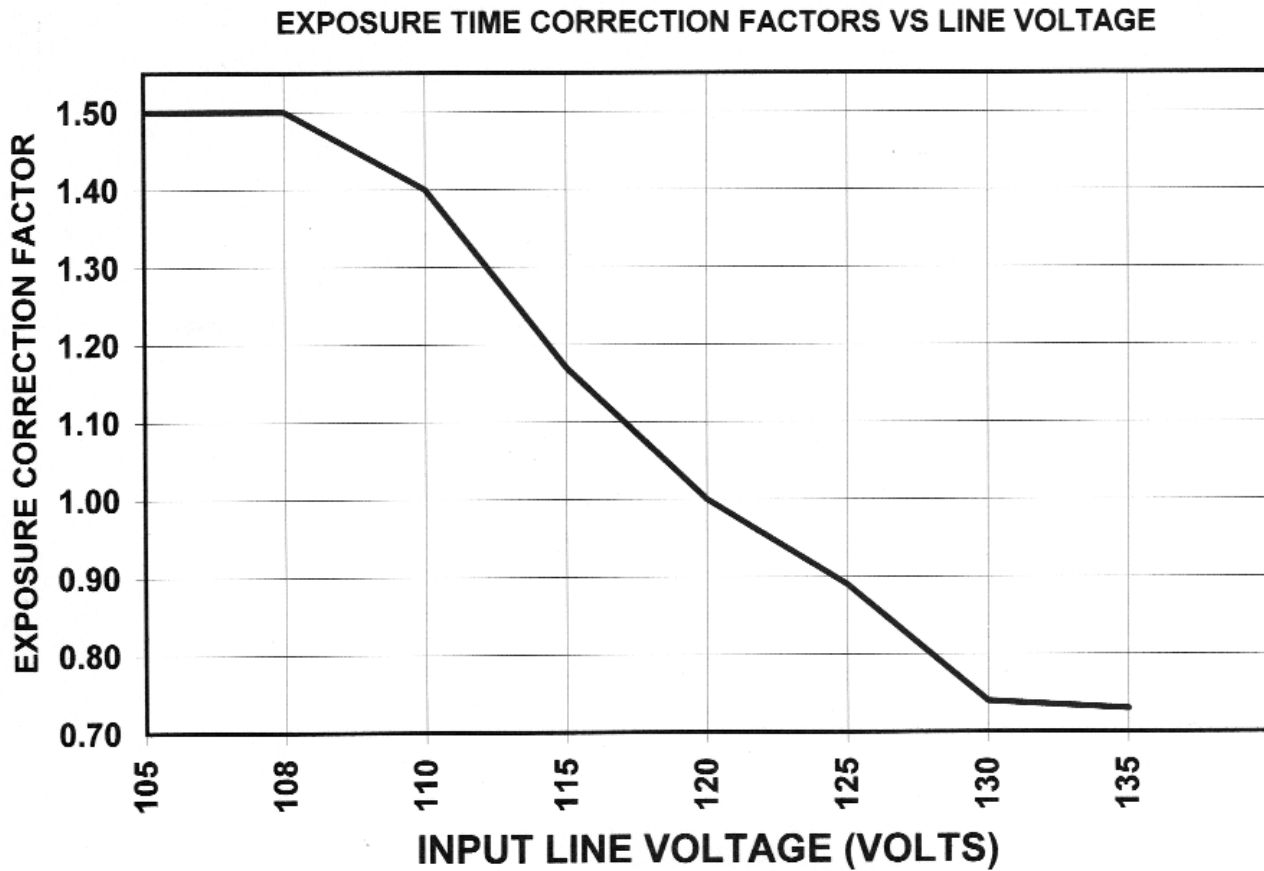

## TECHNICAL FACTORS MEASURING METHOD

- kVp The kVp is defined as the average of the peak high voltage after pre-heating time and settling. The kVp is assessed with a non-invasive instrument having a  $\pm 1\%$  accuracy at the nominal AC input line voltage.
- mA The output current is defined as the average value of the current after pre-heating time and settling. The output current can be measured by attaching a DC voltmeter (0-10 VDC) to the connections behind the circular cap on the side of the Tubehead yoke. The correlating relationship is 1 volt per mA of tube current.
- t The exposure time is defined as the time measured with a non-invasive meter. Accuracy is verified by using an Innovision 8000 mAx instrument.

## X-RAY TUBE CURVES

### OCX / 70-G Emission characteristics

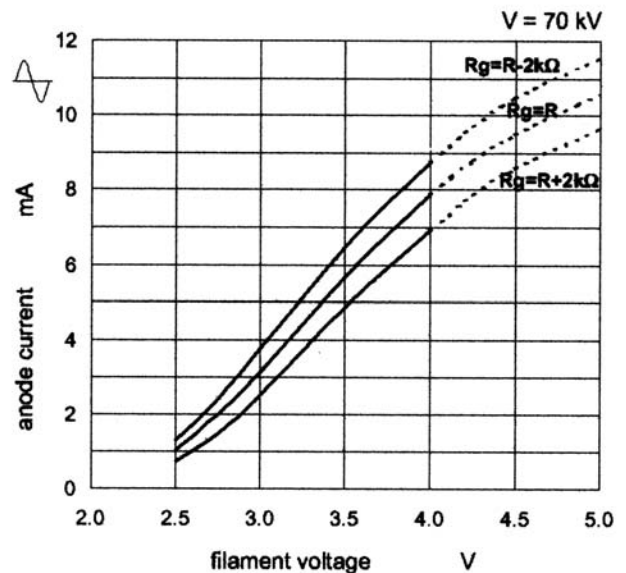
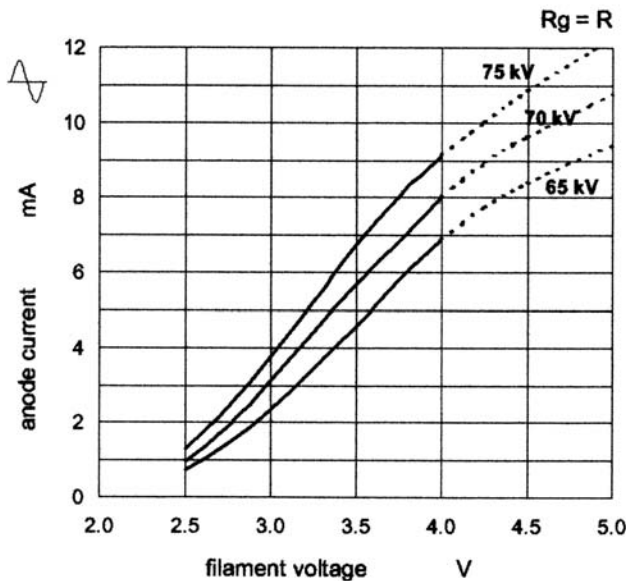

# X-RAY TUBEHEAD KEY COMPONENTS

---

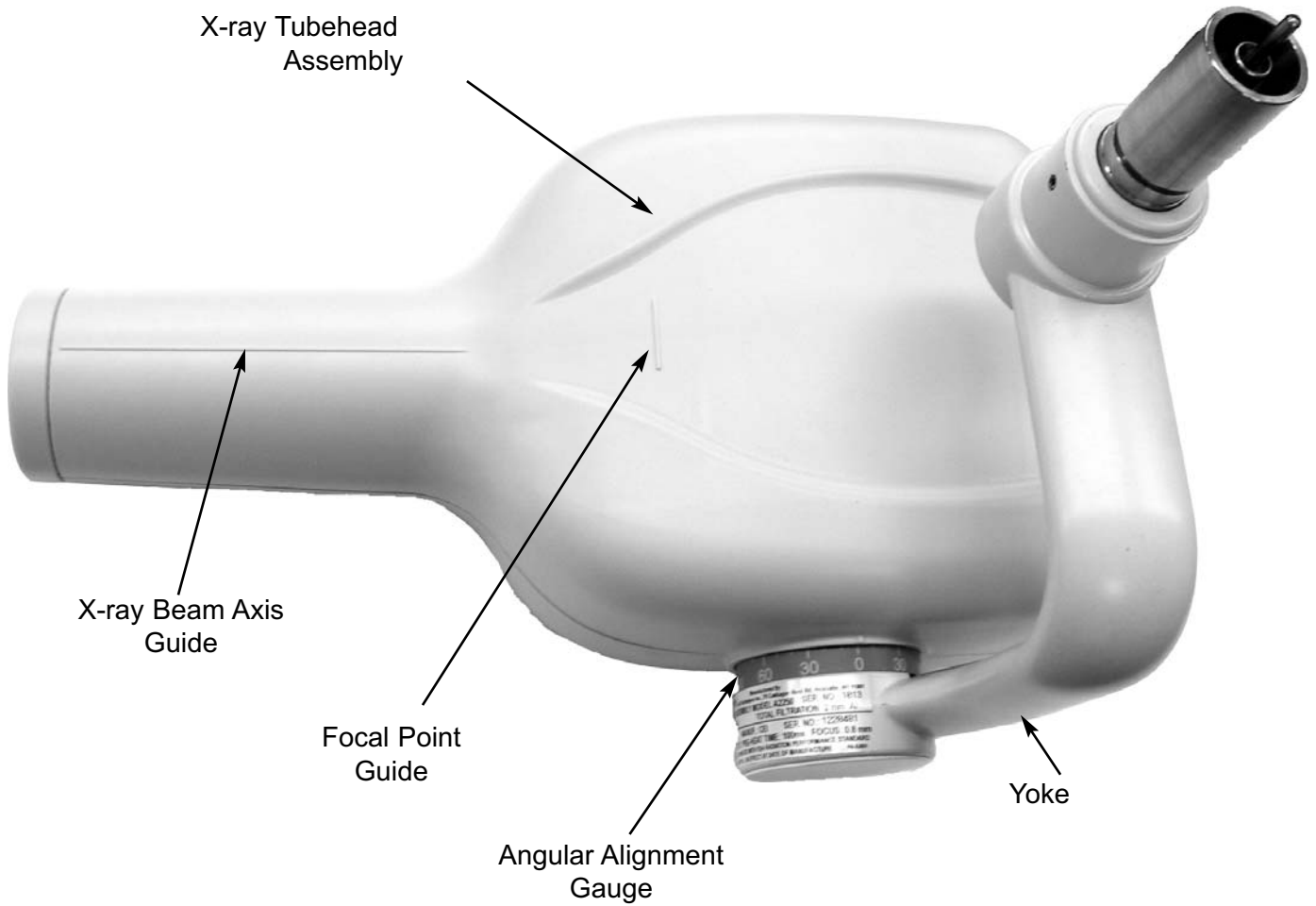

# X-RAY TUBEHEAD SPECIFICATIONS

## Filament Characteristics

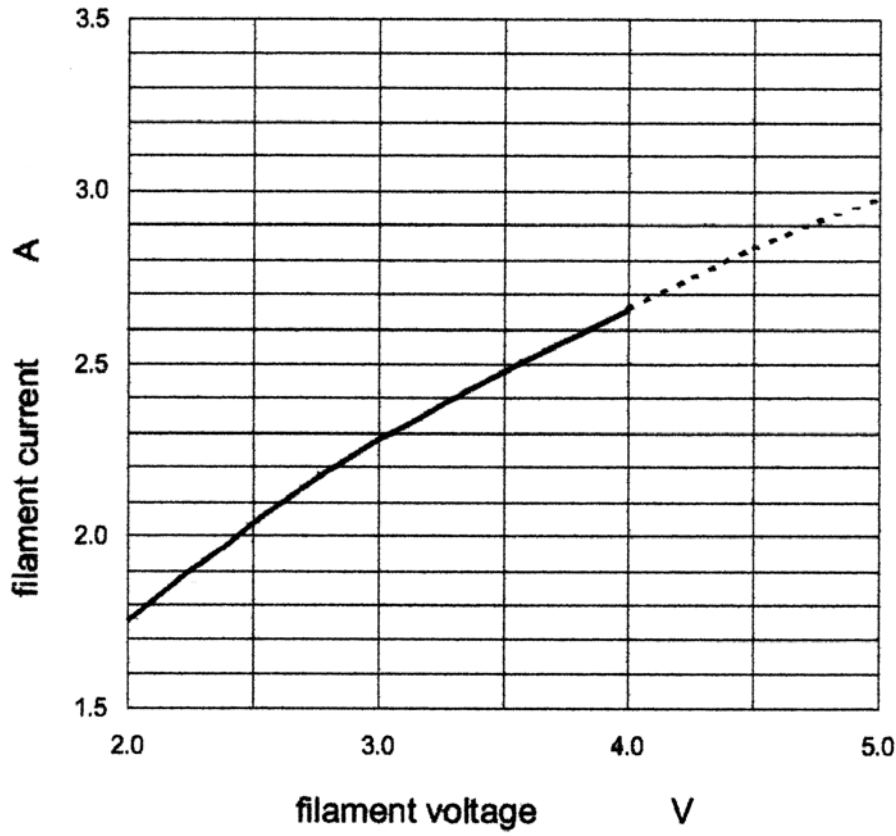

## Loading

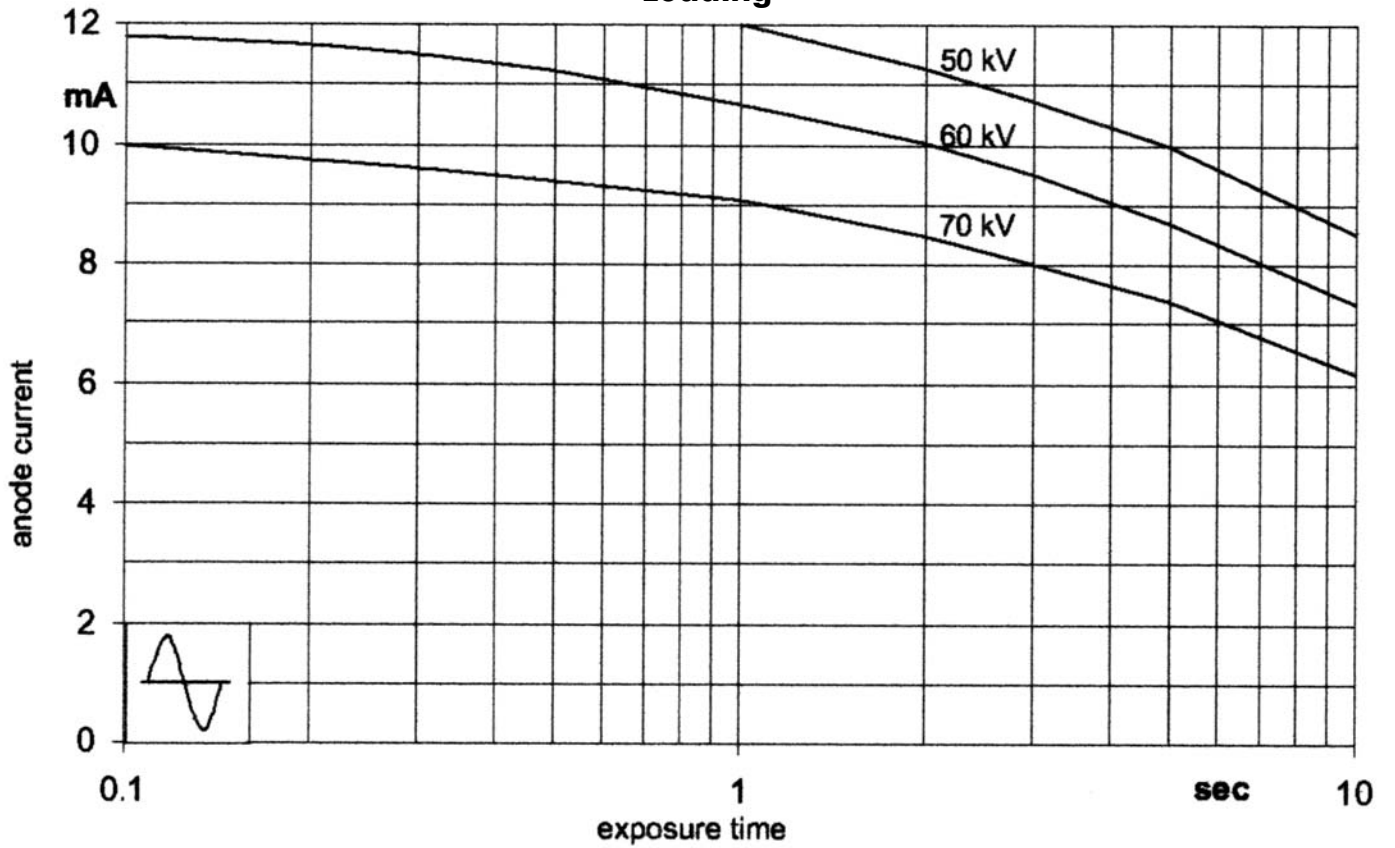

# X-RAY TUBEHEAD SPECIFICATIONS

---

## Cooling

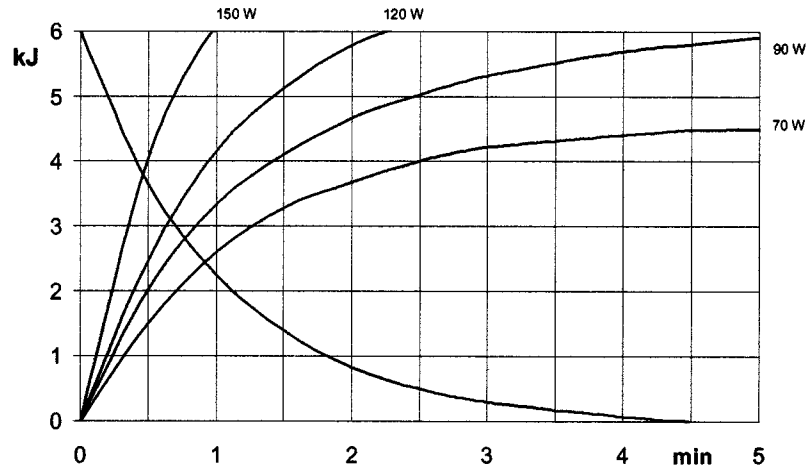

## Cooling curve of Tubehead

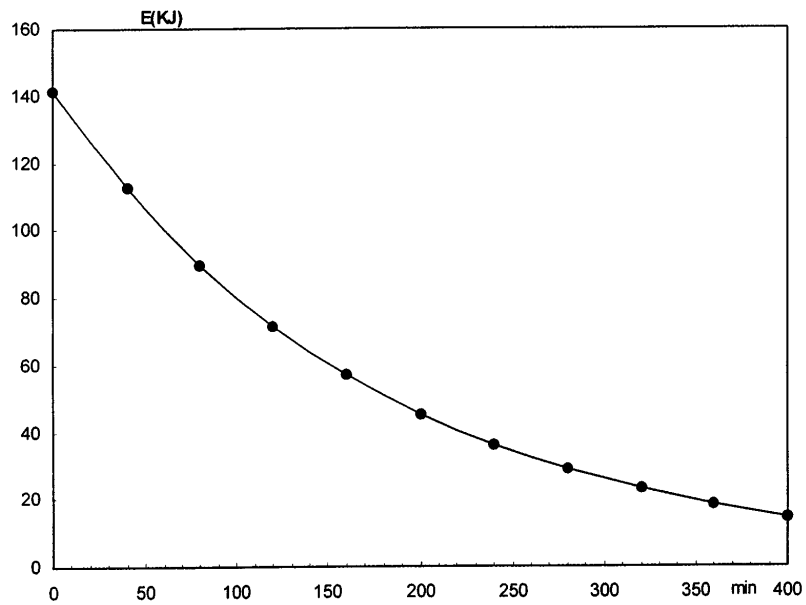

## SYSTEM PORTABILITY

**Note:** Power must be supplied from a dedicated branch circuit rated 15 AMP, 60Hz, 120 Volt. No other equipment may be connected to the branch circuit.

The PROVECTA V is designed to be easily transported among patient operatories as needed. Transport the PROVECTA V by performing the following procedure:

1. Unplug the power line cord from AC wall outlet.
2. Hang power line cord on hook of support platform post.
3. Lower and lock tubehead to support platform post.
4. If necessary, return Handheld Exposure Switch to holder on X-ray Control Panel.
5. Unlock 2 wheel casters.
6. Using hand grips on support platform post, transport the PROVECTA V to next location.
7. Locate the PROVECTA V in desired area and lock the 2 wheel casters.
8. Plug power line cord into AC wall outlet.

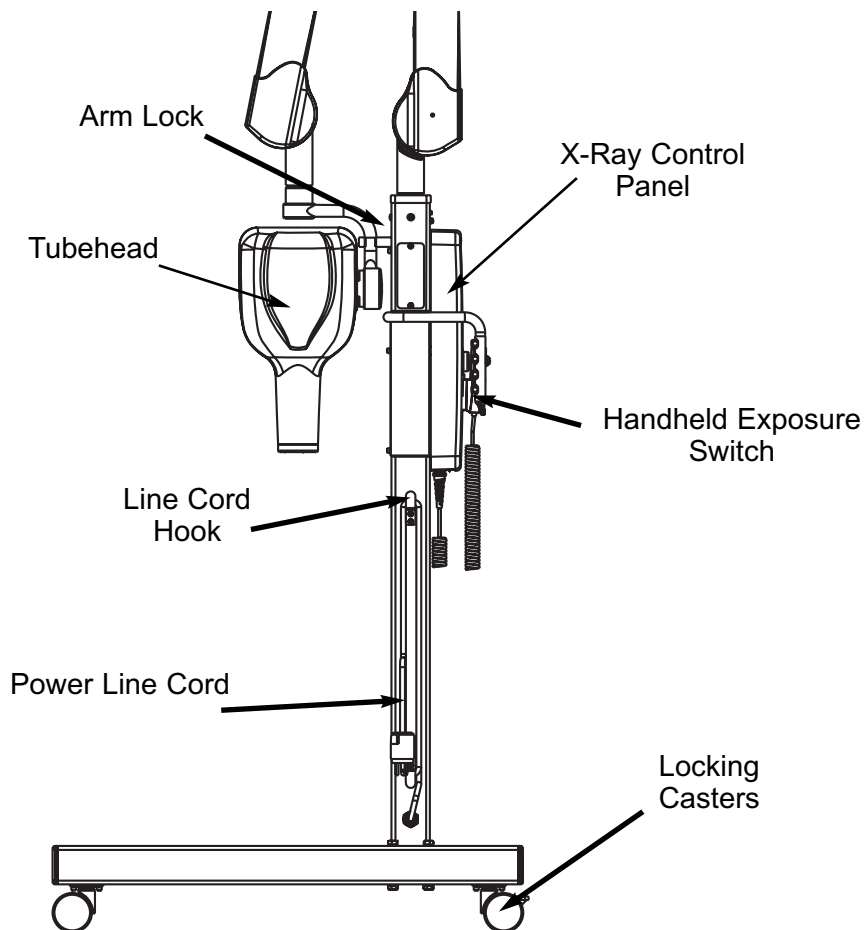

# SYSTEM ACTIVATION

## PROVETA V TURN-ON PROCEDURE:

Turn on the PROVETA V by performing the following procedure:

1. Place the Main Power Switch located on the bottom of the X-Ray Control Panel in the ON ( I ) position.
2. Observe that the system self check function initiates and the digital display displays following sequence :
  - a. **API**
  - b. Display Test **8.8.8**.
  - c. Firmware Version (e.g. A)
  - d. Last setting e.g. (e.g. 0.25)

**Note:** See System Error Messages, pages 31 through 34, for a listing and description of possible start-up error codes.

3. Once the self check function completes successfully, the system starts in the Lower Feline, and Lower Canine Incisors and Exotic, Medium and Film Processor modes and is ready for operation. Verify associated indicator illumination and exposure time display.

**Note:** When power is turned off, the system retains the last selected manual and preset modes. Upon turn on, the system resumes operation as set prior to turning off.

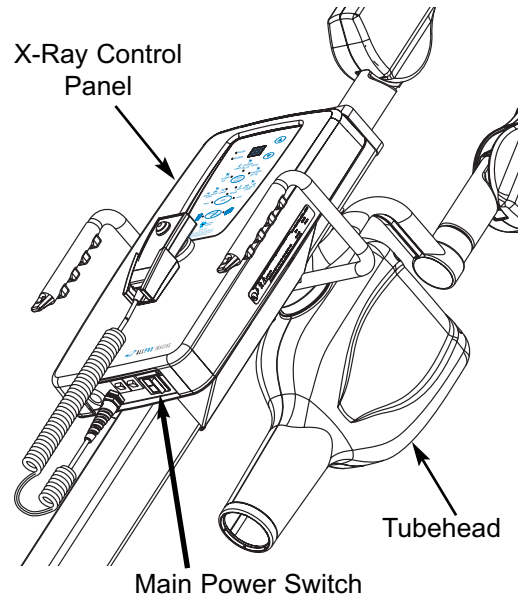



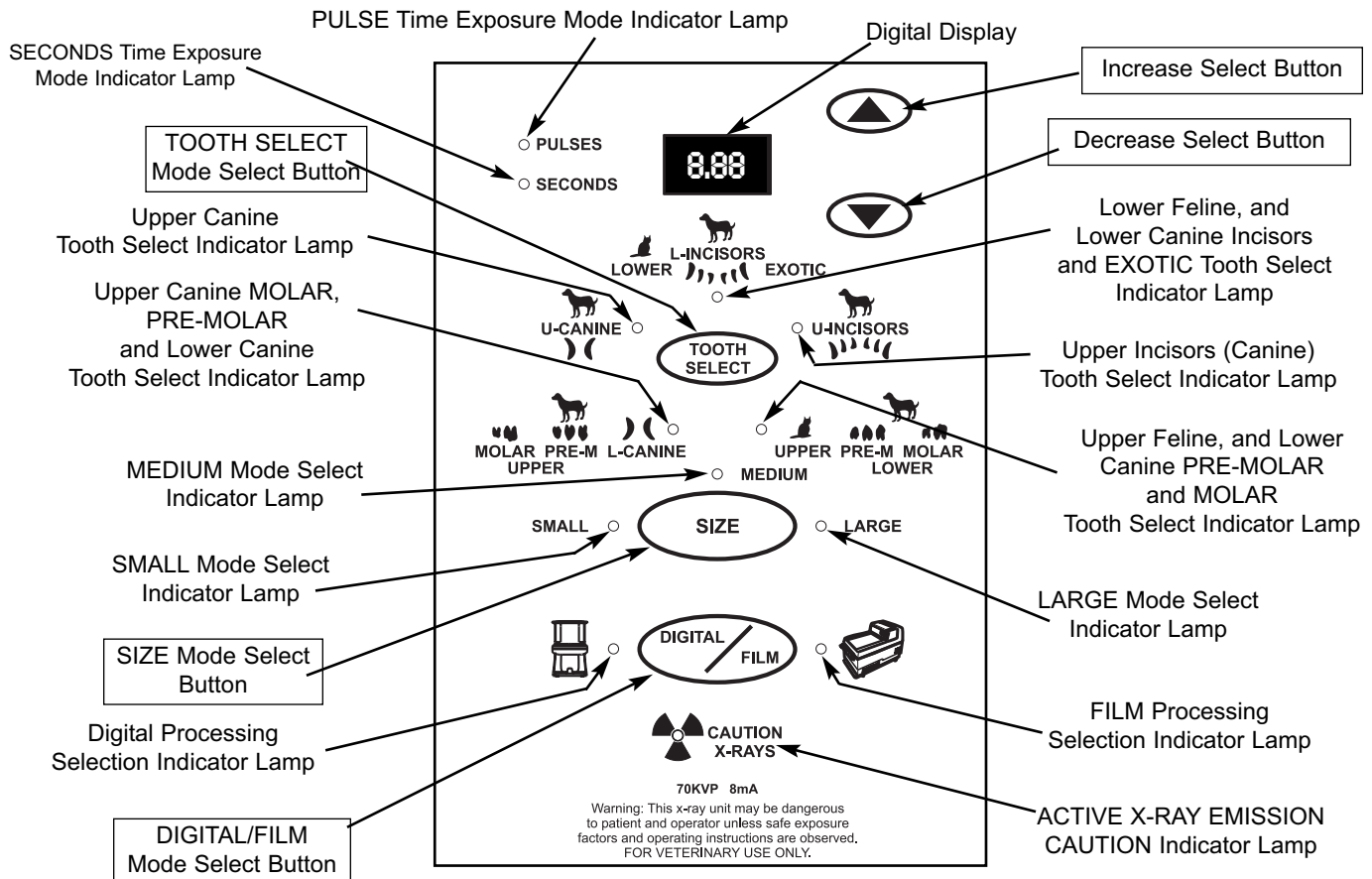















## X-RAY CONTROL PANEL FUNCTIONS



**Note:** All automatic settings are confirmed by the corresponding LED illumination.

# X-RAY CONTROL PANEL FUNCTIONS

**X-Ray Control Panel** - All functional operating control of the PROVECTA V X-Ray is provided by the X-ray Control Panel allowing selection of both automatic and manual of exposure time modes. The 5 automatic selection functions allow the operator to further choose among 30 pre-set times according to the patient type (Small, Medium or Large), tooth type and media type (digital or film). An audible signal sounds during any X-ray emission. In addition, this signal is heard to confirm keypad button selection and when certain errors occur. The location of each panel control and indicator is shown in the preceding illustration, while the function of each is summarized below and described on the following pages.

DIGITAL DISPLAY Panel		A 3-character digital display that shows the selected time value (pulses or seconds) during operational phases as follows: <ol style="list-style-type: none"> <li>1. Exposure Preparation Phase - displays the selected exposure time in both automatic or manual modes.</li> <li>2. Exposure Phase - displays the corrected exposure time adjusted to compensate for variations in the input AC line voltage.</li> <li>3. Cooling Phase - displays remaining tubehead cooling time.</li> </ol>
INCREASE Select Button		A membrane keypad switch that disables all automatic settings and allows the user to manually increase exposure time as necessary.
DECREASE Select Button		A membrane keypad switch that disables all automatic settings and allows the user to manually decrease exposure time as necessary.
PULSE TIME EXPOSURE MODE Indicator Lamp		An LED indicator lamp that illuminates green to confirm selection of the PULSE time mode for Digital Display operation.
SECONDS TIME EXPOSURE MODE Indicator Lamp		An LED indicator lamp that illuminates green to confirm selection of the SECONDS time mode for Digital Display operation.
TOOTH SELECT Mode Select Button		A membrane keypad switch that allows sequential mode selection of preset exposure time among five different teeth categories as follows:
Lower Feline, Lower Canine Incisors and Exotic Tooth Select Indicator Lamp		An LED indicator lamp that illuminates green to confirm selection of preset exposure time for the Lower Feline, Lower Canine Incisors and Exotic tooth categories.
Upper Incisor (Canine) Tooth Select Indicator Lamp		An LED indicator lamp that illuminates green to confirm selection of preset exposure time for the Canine Upper Incisor tooth category.
Upper Feline, and Lower Canine Pre-Molar and Molar Tooth Select Indicator Lamp		An LED indicator lamp that illuminates green to confirm selection of preset exposure time for the Upper Feline, Canine Lower Pre-Molar and Canine Lower Molar tooth categories.
Upper Canine Molar, Pre-Molar and Lower Canine Tooth Select Indicator Lamp		An LED indicator lamp that illuminates green to confirm selection of preset exposure time for the Canine Upper Molar, Canine Upper Pre-Molar and Lower Canine tooth categories.
Upper Canine Tooth Select Indicator Lamp		An LED indicator lamp that illuminates green to confirm selection of preset exposure time for the Upper Canine tooth category.
SIZE Mode Select Button		A membrane keypad switch that toggles between selection of preset exposure time for SMALL, MEDIUM and LARGE exposure modes as follows:
SMALL MODE Indicator Lamp		An LED indicator lamp that illuminates green to confirm selection of preset exposure time for the SMALL exposure mode.
MEDIUM MODE Indicator Lamp		An LED indicator lamp that illuminates green to confirm selection of preset exposure time for the MEDIUM exposure mode.
LARGE MODE Indicator Lamp		An LED indicator lamp that illuminates green to confirm selection of preset exposure time for the LARGE exposure mode.
DIGITAL/FILM Mode Select Button		A membrane keypad switch that toggles between selection of preset exposure time for DIGITAL and FILM exposure modes as follows:
DIGITAL Processing Indicator Lamp		An LED indicator lamp that illuminates green to confirm selection of preset exposure time for the DIGITAL processing mode.
FILM Processing Indicator Lamp		An LED indicator lamp that illuminates green to confirm selection of preset exposure time for the FILM processing mode (D-speed film).
ACTIVE X-RAY EMISSION CAUTION Indicator Lamp		An LED indicator lamp that illuminates yellow to alert the user that x-ray radiation is present during PROVECTA V current operation.

# KEYPAD OPERATION

## INCREASE SELECT BUTTON



## DECREASE SELECT BUTTON



The INCREASE and DECREASE Select Buttons are membrane keypad switches that allow the user to disable the automatic operating mode default time settings (Digital/Film, Size, Tooth Select) and manually increase or decrease exposure time as necessary to any of the 44 values shown below in seconds or pulses.

When a manual exposure time setting is desired, press the associated button (Increase or Decrease) once to display the last manually set exposure time. Manually change the time setting in one increment or decrement by releasing the button and then pressing once. Rapid advancement through the 44 time values is accomplished by keeping the button depressed. Release button to set desired exposure time.

Return to the last automatic mode default time settings by pressing any Mode Selection Button (Digital/Film, Size, Tooth Select).

TIME VALUES IN SECONDS										
0.02	0.04	0.05	0.06	0.08	0.10	0.12	0.14	0.15	0.16	0.18
0.20	0.22	0.23	0.25	0.27	0.28	0.30	0.32	0.33	0.35	0.36
0.38	0.40	0.42	0.43	0.45	0.47	0.50	0.55	0.60	0.63	0.70
0.80	0.90	1.00	1.25	1.30	1.40	1.60	2.00	2.50	3.00	3.20

TIME VALUES IN PULSES										
1	2	3	4	5	6	7	8	9	10	11
12	13	14	15	16	17	18	19	20	21	22
23	24	25	26	27	28	30	33	36	38	42
48	54	60	75	78	84	96	120	150	180	192

## TOOTH SELECT MODE SELECT BUTTON

A membrane keypad switch located in the center of the tooth symbols allows sequential mode selection of preset default exposure times for each of the five indicated teeth types. Each time the TOOTH SELECT Mode Select Button, shown below, is pressed, the associated LED lamp illuminates and an audible signal sounds to indicate selection. Default Preset exposure times are based on D-speed film.

The five selectable default preset exposure times correlating to tooth categories are as follows:

- Lower Feline, Lower Canine Incisors and Exotic 0.10 seconds
- Upper Incisor (Canine) 0.12 seconds
- Upper Feline, Lower Canine Pre-Molar and Canine Molar 0.15 seconds
- Upper Canine Molar, Canine Pre-Molar and Lower Canine 0.20 seconds
- Upper Canine 0.25 seconds

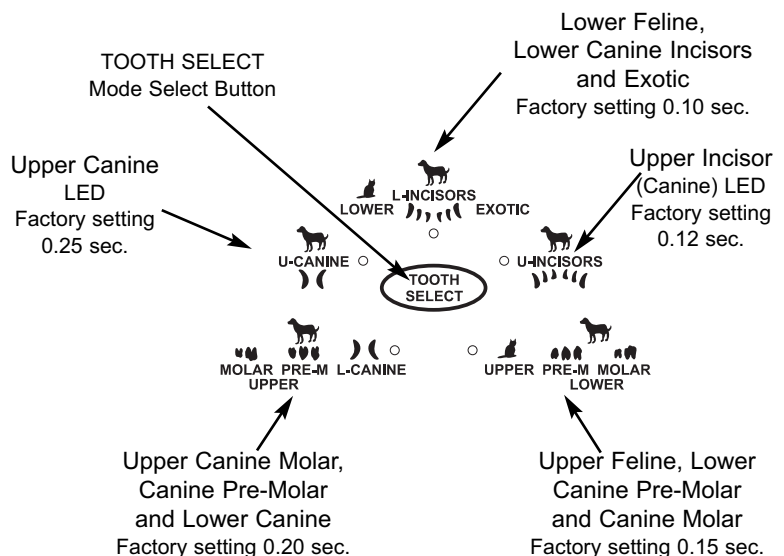

# KEYPAD OPERATION

## SIZE MODE SELECT BUTTON

A membrane keypad switch that switches among the selection of SMALL, MEDIUM and LARGE preset exposure time exposure modes. Each time the SIZE Mode Select Button is pressed, the selection of Small, Medium and Large modes is made with the resulting change in exposure time. The associated LED lamp illuminates and an audible signal sounds to indicate selection.

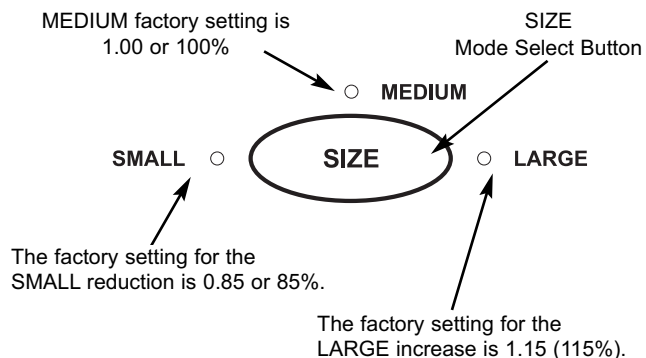

## DIGITAL/FILM MODE SELECT BUTTON

A membrane keypad switch that toggles between automatic exposure settings for specific media types commonly used with the PROVECTA V. The user can select between D-speed film and digital radiology processing. When the FILM mode is selected the system is set to process film at 100% exposure time of D-speed film. When set in the DIGITAL mode, the exposure time is reduced to values suitable for the use of digital phosphor plate scanners such as A/T ScanX.

An audible signal is sounded each time the DIGITAL/FILM Mode Select Button is depressed and the associated LED is illuminated to indicate selection.

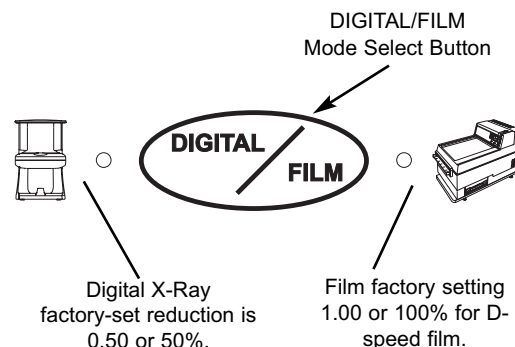

## DEFAULT EXPOSURE TIME SETTINGS

The following table lists the factory-set default setting combinations available by the operation of the TOOTH SELECT, SIZE and DIGITAL/FILM Mode Select Buttons.

**PROVECTA V Available Preset Exposure Time Setting Combinations**

TOOTH SELECT	SMALL				MEDIUM				LARGE			
	SECONDS	PULSES	SECONDS	PULSES	SECONDS	PULSES	SECONDS	PULSES	SECONDS	PULSES	SECONDS	PULSES
L-INCISORS EXOTIC	0.04	3	0.09	5	0.05	3	0.10	6	0.06	3	0.12	7
U-INCISORS	0.05	3	0.10	6	0.06	4	0.12	7	0.07	4	0.14	8
UPPER PRE-M MOLAR LOWER	0.06	4	0.13	8	0.08	5	0.15	9	0.09	5	0.17	10
MOLAR PRE-M L-CANINE UPPER	0.09	5	0.17	10	0.10	6	0.20	12	0.12	7	0.23	14
U-CANINE	0.11	6	0.21	13	0.13	8	0.25	15	0.14	9	0.29	17

# KEYPAD OPERATION: CUSTOM PROGRAMMING

---

**Note:** When power is turned off, the system retains the last selected manual and preset modes. Upon turn on, the system resumes operation as set prior to turning off.

## CHANGING DEFAULT SETTINGS TO CUSTOMIZE VALUES

The PROVECTA V factory default settings are based on D-speed film exposure with the digital display set to show time values in seconds. These defaults allow automatic operation of the system by the selection of the TOOTH SELECT, SIZE and DIGITAL/FILM Mode Select Buttons. Although this automatic operation is adequate for most applications, the PROVECTA V may be customized to meet the needs of a specific application or individual preference.

Customize one or all of the six default settings listed below as necessary by performing the procedures provided by the following paragraphs. When all changes have been accomplished, resume operation of the PROVECTA V per System Operation instructions provided on page 25.

1. Changing Display to Pulses
2. Changing Display to Seconds
3. Changing Default Tooth Setting
4. Changing Default Large and Small Multiplier Ratio
5. Changing Film Multiplier Ratio Settings
6. Changing Digital Multiplier Ratio Settings

## CHANGING DISPLAY TO PULSES

The PROVECTA V is set at the factory to display exposure times in seconds. Perform the following procedure to change the Digital Display panel to show time values in pulses:

1. Turn the Power Switch OFF (0) and then to ON (1) again.
2. When **API** is shown in the Digital Display panel, press and hold the INCREASE (▲) Select Button until **PUL** (pulses) appears in the display window. Verify that the PULSES indicator illuminates on the control panel.
3. Release the INCREASE (▲) Select Button.

## CHANGING DISPLAY TO SECONDS



When the PROVECTA V was changed to display in pulses and there is a need to change the time value back to seconds, perform the following procedure:

1. Turn the Power Switch OFF (0) and then to ON (1) again.
2. When **API** is shown on the Digital Display panel, press and hold the INCREASE (▲) Select Button until **SEC** (seconds) appears in the display window. Verify that the SECONDS indicator illuminates on the control panel.
3. Release the INCREASE (▲) Select Button.

# KEYPAD OPERATION: CUSTOM PROGRAMMING





## CHANGING DEFAULT TOOTH SETTINGS (0.02 to 3.20 Seconds)

The PROVECTA V provides 5 tooth settings and is factory set to start operation in the LOWER Feline, Canine L-INCISORS and EXOTIC tooth select mode. Perform the following procedure to change one or all of the default tooth settings:

1. Turn the Power Switch OFF (0) and then to ON (1) again.
2. Verify that upon device turn on, the firmware version (e.g. A) is displayed on the Digital Display panel as the second display item.
3. When the device firmware version (e.g. A) is displayed, press the  TOOTH SELECT Mode Select Button to enter the default tooth setting programming mode.
4. When **SEL** is shown on the Digital Display panel, press the INCREASE (▲) Select Button. One of the five tooth select indicator lamps will flash and the Digital Display panel will show the current programmed default exposure setting for the selected tooth.
5. Within **ten seconds**, repeatedly press the INCREASE (▲) Select Button until the desired tooth category is selected.
6. Press the  TOOTH SELECT Mode Select Button to confirm selection.
7. The Digital Display panel will flash together with the indicator lamp of the selected tooth to indicate the default setting can be changed.
8. Within ten seconds, press the INCREASE (▲) or DECREASE (▼) Select Button to the desired default setting.
9. Within ten seconds, press the  TOOTH SELECT Mode Select Button to exit the default tooth setting program.
10. Repeat steps 1- 9 until all desired tooth setting changes have been made.

## CHANGING DEFAULT LARGE (1.00 to 2.00) AND SMALL (0.05 to 1.00) MULTIPLIER RATIOS

The PROVECTA V default Large setting is 115% (1.15 ) of the Medium setting while the Small setting is 85% (0.85 )of Medium. Perform the following procedure to change the default LARGE and SMALL mode multiplier ratio settings:

1. Turn the Power Switch OFF (0) and ON (1) again.
2. Verify that upon device turn on, the firmware version (e.g. A) is displayed on the Digital Display panel as the second display item.
3. When the firmware version (e.g. A) is displayed on the Digital Display panel, press the  SIZE Mode Select Button to enter the LARGE multiplier ratio programming mode.
4. When the **L** is shown on the Digital Display panel, press the  TOOTH SELECT Mode Select Button to confirm the LARGE mode selection. (See step 8 for SMALL mode.)
5. Verify that the Digital Display panel shows the factory setting of **1.15** for the LARGE mode multiplier ratio setting.
6. Within **10 seconds** press the INCREASE (▲) or DECREASE (▼) Select Button to set the desired multiplier ratio with respect to D-speed film.
7. Within **10 seconds** of selecting the desired multiplier ratio press the  TOOTH SELECT Mode Select Button to select change.
8. With the **L** shown on the Digital Display panel, press the INCREASE (▲) Select Button to confirm the SMALL mode selection (**S** is shown on the Digital Display panel).
9. When the **S** is shown on the Digital Display panel, press the  TOOTH SELECT Mode Select Button to confirm the SMALL mode selection and verify that the Digital Display panel shows the factory setting of **0.85** for the SMALL mode multiplier ratio setting.
10. Set the desired SMALL mode multiplier ratio with respect to D-speed film by performing steps 6 and 7 above.



# KEYPAD OPERATION: CUSTOM PROGRAMMING

---

**Note:** If using film other than D-Speed film, change the film multiplier ratio as recommended by the film manufacturer prior to use.



## CHANGING FILM MULTIPLIER RATIO SETTING (0.05 to 1.50)

The PROECTA V default FILM setting is 100% (1.00) of D-speed film exposure time. Perform the following procedure to change the default film multiplier ratio setting:

1. Turn the Power Switch OFF (0) and ON (1) again.
2. When the firmware version (e.g. A) is displayed, press the  DIGITAL/FILM Mode Select Button to enter the DIGITAL/FILM multiplier ratio programming mode.
3. When **FIL** is shown on the Digital Display panel, press the  TOOTH SELECT Mode Select Button to confirm the film selection mode.
4. Verify that the Digital Display panel shows the factory setting of **1.00** (100% of D-speed film exposure time).
5. Within **10 seconds** press the INCREASE (▲) or DECREASE (▼) Select Button to set the desired multiplier ration with respect to D-speed film exposure time.
6. Within **10 seconds** press the  TOOTH SELECT Mode Select Button to select.

## CHANGING DIGITAL MULTIPLIER RATIO SETTING (0.05 to 1.50)

The PROECTA V default DIGITAL setting is 50% (0.50) of the FILM setting (D-speed film exposure time). Perform the following procedure to change the default digital media multiplier ratio settings:

1. Turn the Power Switch OFF (0) and ON (1) again.
2. When the firmware version (e.g. A) is displayed, press the  DIGITAL/FILM button to enter the DIGITAL/FILM multiplier ratio programming mode.
3. When **FIL** is shown on the Digital Display panel, press the INCREASE (▲) Select Button.
4. Verify that the Digital Display panel shows **DIG** to confirm the film selection mode.
5. Press the  TOOTH SELECT Mode Select Button to confirm selection.
6. Verify that the Digital Display panel shows the factory setting of **0.50**.
7. Within **10 seconds** press the INCREASE (▲) or DECREASE (▼) Select Button to set the desired multiplier ratio with respect to D-speed film exposure time.
8. Within **10 seconds** press the  TOOTH SELECT Mode Select Button to select.

## FACTORY RESET

Performing factory reset returns all operating values and settings of the PROECTA V to the values set at the factory during manufacture. Refer to the PROECTA V Available Preset Exposure Time Setting Combinations table on page 21 for a listing of the factory-set default exposure settings. Make sure to write down all manually customized settings prior to performing the factory reset sequence. Any settings changed during operation will be lost upon completion of reset. Reset all operating values and settings by performing the following procedure.









1. Turn the Power Switch OFF (0) and then to ON (1) again.
2. When the initials **API** appear in the Digital Display panel, press and hold the DECREASE (▼) Select Button until **FAC** (Factory Reset) appears in the display.
3. Verify that the display shows 0.10 seconds and the SECONDS, LOWER Feline, Canine L-INCISORS and EXOTIC, MEDIUM, and FILM LED indicator lamps are illuminated. The PROECTA V is now reset to operate with the factory-set default settings.

## SETTING THE EXPOSURE













The PROVECTA V is normally operated in the automatic operation mode where the selection combinations of the TOOTH SELECT, SIZE and DIGITAL/FILM Mode Select Buttons provide 30 separate default exposure settings for specific exposure applications. These preset exposure time values (seconds or pulses) associated with the mode select button setting combinations are displayed as shown in the table below. The suggested exposure times are based on D-speed film exposure.

**Note:** Keypad button selection is confirmed by the sounding of an audible signal and illumination of the corresponding indicator lamp .

**Automatic Exposure Time Selection -** Perform the following procedure to set the PROVECTA V to operate in the automatic mode using preset exposure time values.

1. Press any Mode Selection Button    (Tooth Select, Digital/Film, Size) to initiate the automatic exposure mode of operation.
2. Press the  SIZE Mode Select Button to select the patient size parameter. Verify that the corresponding SMALL Mode, MEDIUM Mode or LARGE Mode indicator lamp illuminates and audible signal sounds for the desired preset exposure setting selection.
3. Press the  DIGITAL/FILM Mode Select Button to select the type of media processing. Verify that the corresponding indicator lamp  Digital Mode or  Film Mode illuminates and audible signal sounds for the desired preset exposure setting selection.
4. Press the  TOOTH SELECT Mode Select Button to sequentially advance through the 5 tooth categories until the corresponding indicator lamp illuminates for the desired tooth type selection. The resultant exposure setting is shown on the Digital Display in seconds or pulses as required.

**PROVECTA V Available Preset Exposure Time Setting Combinations**

	SMALL				MEDIUM				LARGE			
												
	SECONDS	PULSES	SECONDS	PULSES	SECONDS	PULSES	SECONDS	PULSES	SECONDS	PULSES	SECONDS	PULSES
	0.04	3	0.09	5	0.05	3	0.10	6	0.06	3	0.12	7
	0.05	3	0.10	6	0.06	4	0.12	7	0.07	4	0.14	8
	0.06	4	0.13	8	0.08	5	0.15	9	0.09	5	0.17	10
	0.09	5	0.17	10	0.10	6	0.20	12	0.12	7	0.23	14
	0.11	6	0.21	13	0.13	8	0.25	15	0.14	9	0.29	17

# SYSTEM OPERATION

---

**Note:** If using other than D-Speed film, change the film multiplier ratio as recommended by the film manufacturer prior to use (refer to the section on Custom Programming on page 22).

The PROECTA V also allows the user to manually set exposure settings to meet the needs of specific patient applications or individual user preference. Using the INCREASE (▲) or DECREASE (▼) Select Buttons, the manual exposure selection mode enables the user to set exposure time values (seconds or pulses) as required. These user-set exposure time values offer 44 specific value settings shown in the tables below.

**Manual Exposure Time Selection-** Perform the following procedure to set the PROECTA V to operate in the manual exposure selection mode using user-set exposure time values.

1. Press either the INCREASE (▲) or DECREASE (▼) Select Buttons to initiate the manual exposure selection mode of operation. The Digital Display panel shows the last manually set exposure time.

**Note:** When set in the manual exposure selection mode, exposure time is increased by pressing the INCREASE (▲) Select Button and decreased by pressing the DECREASE (▼) Select Button. The resultant exposure setting is shown on the Digital Display panel in seconds or pulses.

2. Press either the INCREASE (▲) or DECREASE (▼) Select Buttons once to manually change the time setting in one increment or decrement. Rapid advancement through the entire range of 44 time values is accomplished by keeping the button depressed. Release button to set desired exposure time.
3. Verify that the desired exposure time value is shown on the Digital Display panel.

TIME VALUES IN SECONDS										
0.02	0.04	0.05	0.06	0.08	0.10	0.12	0.14	0.15	0.16	0.18
0.20	0.22	0.23	0.25	0.27	0.28	0.30	0.32	0.33	0.35	0.36
0.38	0.40	0.42	0.43	0.45	0.47	0.50	0.55	0.60	0.63	0.70
0.80	0.90	1.00	1.25	1.30	1.40	1.60	2.00	2.50	3.00	3.20

TIME VALUES IN PULSES										
1	2	3	4	5	6	7	8	9	10	11
12	13	14	15	16	17	18	19	20	21	22
23	24	25	26	27	28	30	33	36	38	42
48	54	60	75	78	84	96	120	150	180	192

## EXPOSURE EMISSION PROCEDURE

1. Introduce the film, plate or sensor into the patient's mouth according to the chosen technique (bisecting or parallel).
2. Move the Tubehead beam limiter near the patient and direct it exactly towards the tooth under examination.
3. Arrange the Tubehead with an angle suitable for the required exposure and positioning.
4. Select exposure time value via either the automatic or manual exposure time operating mode as follows:
  - a. Set automatic exposure settings for specific patient size, media type and tooth type per procedure of page 25.
  - b. Set manual exposure settings as necessary per procedure of page 26.
5. Move as far away as the hand control cable allows, in a direction opposite to the X-ray beam emission while maintaining visual contact with the X-ray Control panel and the patient.
6. Press the X-ray Exposure button and **hold it** depressed throughout the entire exposure.
7. The X-ray emission condition is indicated by the illumination of the ACTIVE X-RAY EMISSION CAUTION Indicator Lamp  and an audible signal sounding.
8. At the end of the exposure, the system starts the Tubehead cooling cycle, which is 32 times the exposure time. The remaining cooling time is shown on the Digital Display panel.

## WARNINGS:

1. The X-ray Exposure button is a "Dead Man" control. **The button must be kept depressed throughout the entire exposure.** Releasing the button before the end of the exposure terminates the emission. When this happens the exposure time display flashes, while the other panel indicators extinguish. The flashing display lasts until either the INCREASE (▲) or DECREASE (▼) button is depressed. At that time, system operation resumes in the tubehead cooling cycle and the display shows remaining cooling time.
2. If the combination of low AC line voltage and long exposure time results in a corrected exposure time of more than 4.00 seconds (240 pulses), the system will inhibit the exposure. In this case, the display shows the corrected exposure time. Reset the unit by pressing the INCREASE (▲) or DECREASE (▼) button and reduce the exposure setting so as not exceed 4.00 seconds (240 pulses).
3. If the AC line voltage reaches minimum/maximum operating limits, the display shows the following:
  - Error Code "LLL" denotes that the voltage is too low (under 106 Volts).
  - Error Code "HHH" denotes that the voltage is too high (over 134 Volts).Contact your ALLPRO Imaging authorized Dealer for service when either code is displayed.

## READING THE EXPOSURE COUNTER

1. Simultaneously press and hold the INCREASE (▲) and DECREASE (▼) Select Buttons for more than 3 seconds.
2. When **P20** is shown on the Digital Display panel, release the INCREASE (▲) and DECREASE (▼) Select Buttons.
3. Press either the INCREASE (▲) or DECREASE (▼) Select Button to display the number of exposures in thousands (e.g. 004=4,000).
4. Press the INCREASE (▲) or DECREASE (▼) Select Button to display the number of exposures up to 999 (e.g. 354).
5. The total number of exposures is  $4,000 + 354 = 4,354$ .
6. Press the  TOOTH SELECT Button to exit the exposure counter mode.

# SYSTEM REACH AND STORAGE DIMENSIONS

The following illustration shows the operational footprint and the necessary space required to store the PROVECTA V.

**Note:** With the casters unlocked the PROVECTA V X-ray Support Platform allows 360-degree movement, which is only limited by the connection of the AC power cord .

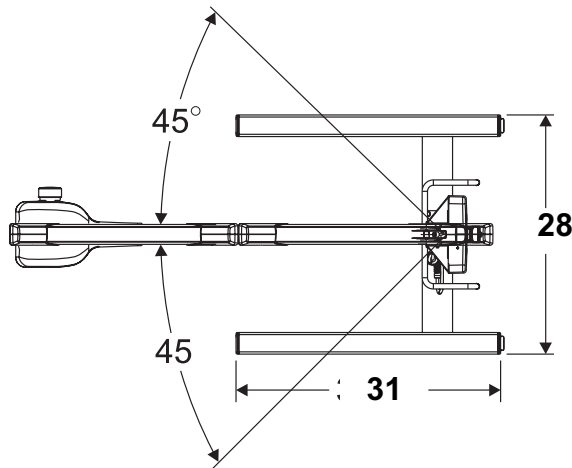

**Mobile X-Ray Dimensions:  
79 1/2" H x 28" W x 31" D**

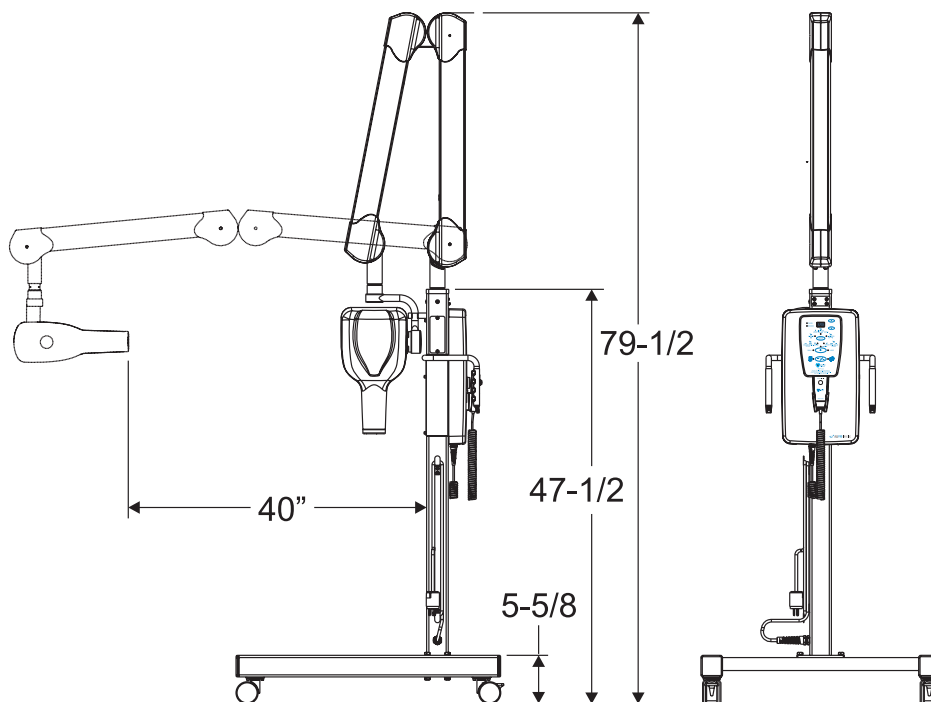

## CHECKS AND CORRECTION OF POSSIBLE FAULTS IN DENTAL RADIOGRAPHS

### TYPICAL DEFECTS OF INTRA-ORAL RADIOLOGY

#### - Light Radiographs:

Possible causes:

- Insufficient exposure to X-ray (short time)
- Poor film processing technique
- Insufficient development time
- Deteriorated developer / contaminated developer
- Developer temperature below recommended value
- Incorrect developing fluid dilution
- Expired film

#### - Dark Radiographs:

Possible causes:

- Excessive exposure to X-ray (long time)
- Film exposed to light / secondary X-ray exposure
- Poor film processing techniques
- Contaminated developer
- Excessive development time
- Developer temperature above recommended value
- Incorrect developing fluid dilution
- Expired film

#### - Blurred Radiographs (details not visible):

Possible causes:

- The patient moved
- The tubehead moved

#### - Radiographs with Herringbone Marks:

Some intra-oral films are provided with a thin lead foil having a herringbone type mark on its lower side. These films may be exposed to radiation on one side only. If the film is exposed on the wrong side, the lead foil will absorb a large amount of radiation during exposure. The result will be a lighter radiograph and the film will show herringbone marks.

# **RADIOGRAPH TROUBLESHOOTING**

---

## **PARTIALLY EXPOSED RADIOGRAPHS**

Possible causes:

- X-ray Tubehead positioned incorrectly with respect to the imaging media
- Low developer fluid level, with resulting partial film development
- Two or more films placed against each other during development

## **CLOUDED RADIOGRAPHS**

Possible causes:

- Outdated film (check expiration date)
- Film accidentally exposed to X-ray
- Film accidentally exposed to other natural or artificial light sources
- Improper development technique

## **RADIOGRAPHS SHOWING A BLACK LINE**

This line appears when the film is excessively folded

## **RADIOGRAPHS SHOWING SIGNS OF ELECTROSTATIC ELECTRICITY**

When a film is compressed too much and the air is dry, static electricity may occur, which displays black marks.

## **RADIOGRAPHS WITH CHEMICAL SPOTS**

Developer or fixer fluid splattered on the film before development and fixing procedures produces spots on the radiograph; such spots are:

- dark, when caused by developer fluid
- light when caused by fixer fluid

## **RADIOGRAPHS WITH EMULSION COMING OFF**

If the film is kept in a hot water bath too long (e.g. throughout the whole night), or in the developer solution too long, the emulsion may become softer and partially come off the film base. After development, the film will show scratches.

## **TYPICAL DEFECTS CAUSED BY INCORRECT POSITIONING**

### **- Radiographs with Elongated or Shortened Image:**

The main beam is not perpendicular to the bisecting angle formed by the tooth longitudinal axis and the film.

### **- Radiographs with Stretched Out Tip of Tooth**

Probably caused by excessive film folding or bending inside patient's mouth.

# SYSTEM MAINTENANCE

---

To ensure the safe and effective performance of the PROECTA V follow the proper operation as described by the instructions in this manual.

Periodic maintenance is determined by observations made by the operator and/or an ALLPRO Imaging Authorized Dealer Field Service Technician. Refer to the PROECTA V Installation & Service Manual for information pertaining to the installation and servicing of the PROECTA V System.

**WARNING: PRE-OPERATION CHECKS MUST BE PERFORMED BEFORE THE PROECTA V SYSTEM IS OPERATED. IF ANY PROBLEMS OR ANOMALIES ARE NOTED, DO NOT OPERATE THE UNIT AND CONTACT YOUR ALLPRO IMAGING AUTHORIZED DEALER FOR SERVICE.**

The operator should observe before any operating session that:

- the unit is solidly secured on its mobile support platform
- the scissor arms are correctly balanced and stable
- the Tubehead is free from oil residues
- the Exposure switch cable is not damaged
- there is no external damage on the X-Ray unit
- the scissor arms are correctly balanced and stable
- the labels and keypad surface are properly secured

## SYSTEM ERROR MESSAGES

---

### ERROR MESSAGES

The PROECTA V has been designed with safety features to protect the patient and operator in case of failure of an electrical component. The system automatically checks for errors and will report a malfunction by means of an error code on the X-ray Control Panel display. These error codes are shown in the table on the following pages. The table lists the code, identifies the potential source of the problem and recommends the corrective action required by the operator to clear the error.

**WARNING: WHEN A PROBLEM IS DETECTED FOLLOW THE IDENTIFIED "ACTION REQUIRED" IN THE ERROR CODE TABLE BELOW AND CALL YOUR ALLPRO IMAGING AUTHORIZED DEALER FOR SERVICE AS REQUIRED.**

**FOR PROPER MAINTENANCE AND SAFETY, SERVICE MUST BE PERFORMED ONLY BY AN ALLPRO IMAGING AUTHORIZED DEALER SERVICE TECHNICIAN.**

**WARNING: IMMEDIATELY REMOVE POWER IF ERROR CODE E02 APPEARS ON THE DISPLAY AND A PULSATING AUDIBLE TONE IS HEARD.**

<b>ERROR CODE</b>	<b>X-RAY GENERATION IS CONTINUOUS AND THE POWER SWITCH MUST BE SET TO THE OFF (0) POSITION TO END EMISSIONS.</b>
<b>E02</b>	<b>CALL YOUR ALLPRO IMAGING AUTHORIZED DEALER FOR SERVICE.</b>

## SYSTEM ERROR MESSAGES

ERROR CODE	AUDIBLE SIGNAL	SOURCE OF ANOMALY	ACTION REQUIRED
E01	None	The X-ray relay is closed when power is turned on. <b>X-RAY GENERATION IS INHIBITED.</b>	Test with Tubehead Simulator. Reset power by turning the Main Power Switch OFF (0) and ON (I). If E01 error repeats, replace the X-ray Control Panel.
E02	Continuously Pulsating	Voltage is present at the Tubehead when power is turned ON (I). This is a result of multiple component failures. <b>X-RAY GENERATION IS CONTINUOUS.</b>	<b>IMMEDIATELY REMOVE POWER. TURN THE POWER SWITCH TO OFF (0).</b> Test with Tubehead Simulator. Reset power by turning the Main Power Switch OFF (0) and then ON (I). If E02 error repeats, replace the X-ray Control Panel.
E05	None	The main or Remote Exposure Switch is depressed when power is turned ON (I). <b>X-RAY GENERATION IS INHIBITED.</b>	Check that the switches are not depressed. Reset power by turning the Main Power switch OFF (0) and then ON (I). If E05 error repeats check the switches and cables for defects or short circuits. Replace Switch assembly.
E07	None	The DIGITAL/FILM button is depressed when power is turned ON (I). <b>X-RAY GENERATION IS INHIBITED.</b>	Check that the Control Panel switch is not depressed. Reset power by turning the Main Power switch OFF (0) and then ON (I). If E07 error repeats, replace Membrane Assembly.
E08	None	The INCREASE button (▲) is depressed when power is turned ON (I). <b>X-RAY GENERATION IS INHIBITED.</b>	Check that the Control Panel switch (▲) is not depressed. Reset power by turning the Main Power switch OFF (0) and then ON (I). If E08 error repeats, replace Membrane Assembly.
E09	None	The DECREASE (▼) button is depressed when power is turned ON (I). <b>X-RAY GENERATION IS INHIBITED.</b>	Check that the Control Panel switch (▼) is not depressed. Reset power by turning the Main Power switch OFF (0) and then ON (I). If E09 error repeats, replace Membrane Assembly.
E10	None	The SIZE button is depressed when power is turned ON (I). <b>X-RAY GENERATION IS INHIBITED.</b>	Check that the Control Panel switch is not depressed. Reset power by turning the Main Power switch OFF (0) and then ON (I). If E10 error repeats, replace Membrane Assembly.

## SYSTEM ERROR MESSAGES

ERROR CODE	.941AUDIBLE SIGNAL	SOURCE OF ANOMALY	ACTION REQUIRED
E12	None	The TOOTH SELECT button is depressed when power is turned ON (I).  <b>X-RAY GENERATION IS CONTINUOUS.</b>	Check that the Control Panel switch is not depressed. Reset power by turning the Main Power switch OFF (0) and then ON (I). If E12 error repeats, replace Membrane Assembly
E20	None	The X-ray relay is not closing within the required time after the Exposure Switch is pressed.  <b>X-RAY GENERATION IS INHIBITED.</b>	Test with Tubehead Simulator. Reset power by turning the Main Power Switch OFF (0) and ON (I). If E20 error repeats, replace the X-ray Control Panel.
E21	Continuously Pulsating	The X-ray relay is not opening within the required time after the exposure is completed.  <b>X-RAY GENERATION IS TERMINATED BY A SAFETY TIMER.</b>	<b>IMMEDIATELY REMOVE POWER. TURN THE POWER SWITCH TO OFF (0).</b> Test with Tubehead Simulator. Reset power by turning the Main Power switch OFF (0) and then ON (I). If E21 error repeats, replace the X-ray Control Panel.
E22	None	The X-ray triac is not closing within the required time after the Exposure Switch is pressed.  <b>X-RAY GENERATION IS INHIBITED.</b>	Test with Tubehead Simulator. Reset power by turning the Main Power Switch OFF (0) and ON (I). If E22 error repeats, replace the X-ray Control Panel.
E23	Continuously Pulsating	The X-ray triac is not opening within the required time after the exposure is completed or the Tubehead is not connected to the X-ray control.  <b>X-RAY GENERATION IS TERMINATED BY A SAFETY TIMER.</b>	<b>IMMEDIATELY REMOVE POWER. TURN THE POWER SWITCH TO OFF (0).</b> Test with Tubehead Simulator. Reset power by turning the Main Power switch OFF (0) and then ON (I). If E23 error repeats, replace the X-ray Control Panel. If E23 error does not repeat, turn the Main Power switch OFF (0) and verify that the resistance at the wires going to the Tubehead is nominally 1.5 ohms. If not, remove the Tubehead and verify the resistance at the Tubehead connector is nominally 1.5 ohms. If not, replace the Tubehead. If yes, check the wiring in the fixed and scissor arms

## SYSTEM ERROR MESSAGES

ERROR CODE	AUDIBLE SIGNAL	SOURCE OF ANOMALY	ACTION REQUIRED
E25	None	The X-ray emission exceeds the programmed time and is terminated by the hardware timer at nominally 5.5 seconds.	Test with Tubehead Simulator. Reset power by turning the Main Power Switch OFF (0) and ON (I). If E25 error repeats, replace the X-ray Control Panel.
LLL	None	The AC input line voltage is less than 106 Volts when the Exposure Switch is pressed.  <b>X-RAY GENERATION IS INHIBITED.</b>	Press the INCREASE (▲) or DECREASE (▼) buttons to reset the display. If LLL error repeats, check the AC line voltage at the input terminals to the X-ray Control Panel
HHH	None	The AC input line voltage is greater than 134 Volts when the Exposure Switch is pressed.  <b>X-RAY GENERATION IS INHIBITED.</b>	Press the INCREASE (▲) or DECREASE (▼) buttons to reset the display. If HHH error repeats, check the AC line voltage at the input terminals to the X-ray Control Panel
Greater than 4.00 seconds or 240 pulses	None	The combination of low AC input line voltage and long selected exposure time when the Exposure Switch is pressed  <b>X-RAY GENERATION IS INHIBITED.</b>	Press the INCREASE (▲) or DECREASE (▼) buttons to reset the display. Reduce the selected exposure time such that the corrected time is less than 4.00 seconds or 240 pulses.
Flashing Exposure Time	None	The Exposure Switch was released prior to the completion of the programmed X-ray emission time.  <b>X-RAY GENERATION WAS PREMATURELY TERMINATED.</b>	Press the INCREASE (▲) or DECREASE (▼) buttons to reset the display.



Air Techniques and ALLPRO Imaging are leading manufacturers of fine dental, medical and veterinary equipment from air and vacuum systems and X-ray film processors, to an impressive line of new products incorporating the most recent technological advances. These new products, vital components of the innovative professional practice, include intraoral cameras, digital imaging systems, which utilizes phosphor plate technology and, most recently, an intraoral digital X-ray system using sensor technology.

Air Techniques and ALLPRO Imaging have been manufacturing quality products for the dental, medical and veterinary professional since 1962.

Air Techniques and ALLPRO Imaging products are distributed only through authorized dealers. Refer to [www.airtechniques.com](http://www.airtechniques.com) or [www.allproimaging.com](http://www.allproimaging.com) to find a dealer in your area.

- Accent™ Intraoral Digital X-ray Image System
- Acclaim® USB Only Intraoral Digital Video Camera System
- Acclaim® Intraoral Digital Video Camera System
- AirStar®
- A/T 2000® XR
- Guardian™ Amalgam Collector
- Peri-Pro®
- Provecta 70™
- ScanX®
- STS™
- VacStar™



1-800-AIR-TECH  
(1-800-247-8324)  
[www.airtechniques.com](http://www.airtechniques.com)

- 100 Plus
- 2010
- Medscope
- Provecta V
- ScanX® 12
- ScanX® 14
- ScanX® DVM
- ScanX® NDT
- ScanX® 12 EV
- ScanX® 14 PORTABLE
- ScanX® NDT PORTABLE



1-800-AIR-TECH  
(1-800-247-8324)  
[www.allproimaging.com](http://www.allproimaging.com)